

Specifications

Model	Line Voltage (VAC)	Armature Voltage Range (VDC)	Continuous Armature Current (Amps)	Horsepower Range
LGP443-3	115	0 - 90	3.0	1/10 - 1/4
	230	0 - 180		1/6 - 1/2
LGP443-10	115	0 - 90	10.0	1/8 - 1
	230	0 - 180		1/4 - 2

AC Line Voltage.....115/230 VAC ± 10%, 50/60 Hz, single phase
Form Factor.....1.37 at base speed
Field Voltage with 115 VAC line voltage.....50 or 100 VDC
with 230 VAC line voltage.....100 or 200 VDC
Maximum Field Current.....1 Amp
Acceleration Time Range.....1 second
Deceleration Time Range.....coast to stop - 1 second
Analog Input Voltage Range (NEG to POS).....0 - 10 VDC
Current Range (NEG to POS).....4 - 20 mA
Input Impedance (S1 to S2) without 1000 ohm RSH resistor.....1000 ohms
with 1000 ohm RSH resistor.....500 ohms
Load Regulation.....1% of base speed or better
Speed Range.....60:1
Vibration (0 - 50 Hz).....0.5G maximum
(>50 Hz).....0.1G maximum
Ambient Temperature Range.....10°C - 55°C
Weight.....1.5 lbs
Safety Certifications.....UL/cUL Recognized Equipment, file # E132235
.....CSA Certified Component, file # LR41380

Safety Warnings

READ ALL SAFETY WARNINGS BEFORE INSTALLING THIS EQUIPMENT

- **DO NOT INSTALL, REMOVE, OR REWIRE THIS EQUIPMENT WITH POWER APPLIED.** Have a qualified electrical technician install, adjust and service this equipment. Follow the National Electrical Code and all other applicable electrical and safety codes, including the provisions of the Occupational Safety and Health Act (OSHA), when installing equipment.
- **Circuit potentials are at 115 or 230 VAC above earth ground.** Avoid direct contact with the printed circuit board or with circuit elements to prevent the risk of serious injury or fatality. Use a non-metallic screwdriver for adjusting the calibration trim pots. Use approved personal protection equipment and insulated tools if working on this drive with power applied.
- Reduce the chance of an electrical fire, shock, or explosion by using proper grounding techniques, over-current protection, thermal protection, and enclosure. Follow sound maintenance procedures.
- **ACE strongly recommends the installation of a master power switch in the line voltage input.** The switch contacts should be rated for 250 VAC and 200% of motor nameplate current.
- **Removing AC line power is the only acceptable method for emergency stopping.** Do not use dynamic braking, decelerating to minimum speed, or coasting to a stop for emergency stopping. They may not stop a drive that is malfunctioning. Removing AC line power is the only acceptable method for emergency stopping.
- Line starting and stopping (applying and removing AC line voltage) is recommended for infrequent starting and stopping of a drive only. Dynamic braking, decelerating to minimum speed, or coasting to a stop is recommended for frequent starts and stops. Frequent starting and stopping can produce high torque. This may cause damage to motors.
- **Do not disconnect any of the motor leads from the drive** unless power is removed or the drive is disabled. Opening any one lead while the drive is running may destroy the drive.
- The field output is for shunt wound motors only. Do not make any connections to F1 and F2 when using a permanent magnet motor.
- Change voltage switch settings only when the drive is disconnected from AC line voltage. Make sure both switches are set to their correct position. If the switches are improperly set to a lower voltage position, the motor will not run at full voltage and may cause damage to the transformer. If the switches are improperly set to a higher voltage, the motor will overspeed, which may cause motor damage, or result in bodily injury or loss of life.
- Under no circumstances should power and logic level wires be bundled together.
- Be sure potentiometer tabs do not make contact with the potentiometer's body. Grounding the input will cause damage to the drive.

Dimensions

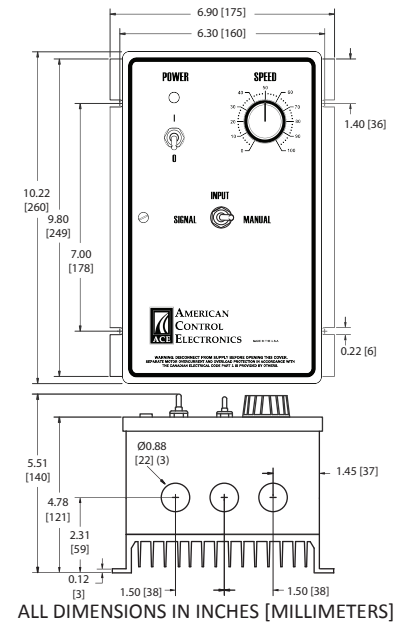

Installation

Mounting

NEMA 4X cased drives come with two 0.88 inch (22 mm) conduit knockout holes at the bottom of the case. The drives may be vertically wall mounted using the four 0.19 inch (5 mm) slotted holes on the attached heat sink. For loads less than 5 amps, the drives may be bench mounted horizontally or operated without mounting.

1. Install the mounting screws.
2. For access to the terminal strip, turn the slotted screw on the front cover counterclockwise until it is free from the case. The right side of the cover is hinged to the case. Pull the slotted screw to open the case.
3. Carefully remove the conduit knockouts by tapping them into the case and twisting them off with pliers.
4. Set the POWER switch to the OFF position before applying AC line voltage.
5. Install conduit hardware through the 0.88 inch (22 mm) knockout holes. Connect external wiring to the terminal block.
6. Grasp the slotted screw and tilt the front cover back into place. Avoid pinching any wires between the front cover and the case.
7. Turn the slotted screw clockwise until tight to secure the front cover.

Wiring

Use 18 - 24 AWG wire for logic wiring. Use 14 - 16 AWG wire for AC line and motor wiring.

Shielding Guidelines

As a general rule, ACE recommends shielding of all conductors. If it is not practical to shield power conductors, ACE recommends shielding all logic-level leads. If shielding of logic-level leads is not practical, the user should twist all logic leads with themselves to minimize induced noise. It may be necessary to earth ground the shielded cable. If noise is produced by devices other than the drive, ground the shield at the drive end. If noise is generated by the drive, ground the shield at the end away from the drive. Do not ground both ends of the shield.

Fusing

ACE drives require an external line fuse for protection. Use fast acting fuses rated for 250 VAC or higher and 150% of the maximum armature current. Fuse the HOT leg of the AC line when using 115 VAC and both lines when using 230 VAC.

Connections

Line Input

Connect the AC line power leads to terminals 1 and 2 if using 115V line power or to terminals 1 and 3 if using 230 VAC line power.

Motor

Connect the DC armature leads to terminals 4 and 4. If the motor does not spin in the desired direction, power down the drive and reverse these connections.

Field

At 115 VAC, connect the field leads to terminals 1 and 6 for a 50 VDC field or to 6 and 7 for a 100 VDC field. At 230 VAC, connect the field leads to terminals 1 and 6 for a 100 VDC field or to 6 and 7 for a 200 VDC field.

Do not make any connections to F1 and F2 if using a permanent magnet motor.

Analog Input Signal Range

LGP403 series drives are designed to follow an analog input signal. This input signal can be in the form of voltage (0-10 VDC) or current (4-20 mA). Because these drives have built in isolation, the input signal can be grounded or ungrounded (floating). Connect the signal common (-) to terminal 9 and the signal reference (+) to 8. If using a 4-20 mA signal, place a 1000 ohm (1K) resistor across the RSH terminals. If using a 0-10 VDC signal, leave the RSH terminals open. By default, LGP403 series drives are setup so that when the switch on the front cover is set to MANUAL, the drive will run in Ratio Mode (where the potentiometer on the cover sets the ratio of the analog input signal). To wire the drive for Manual Mode, so that drive follows the potentiometer on the front cover regardless of the external analog signal, see the Operations section.

POWER

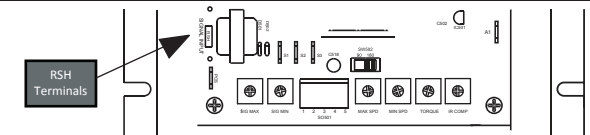

LOGIC

115 VAC INPUT

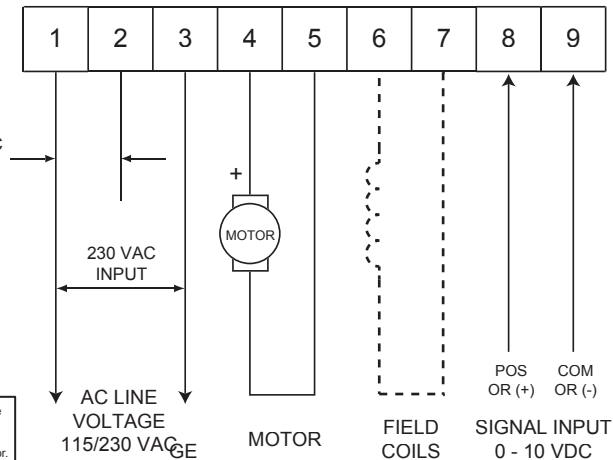

NOTE: DO NOT make any connections to F1 and F2 if using a permanent magnet motor.

Startup

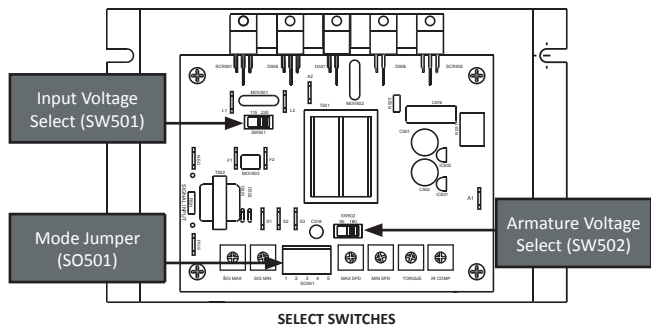

Input Voltage Select (SW501)
Set the voltage switch SW501 to either 115V or 230V to match the AC line voltage.

Armature Voltage Select (SW502)
Set the voltage switch SW502 to either 90V or 180V to match the maximum armature voltage.

MODE JUMPER

The LGP443 series drives comes preset for the Signal / Ratio Switch configuration.

Manual Mode: In Manual mode, the drive will follow a speed potentiometer connected to terminals S1, S2, and S3. Any input voltage signal on terminals NEG and POS will have no effect.

Signal Mode: In Signal mode, the drive will follow an input voltage or current signal connected to terminals NEG and POS. Any speed potentiometer on terminals S1, S2, and S3 will have no effect.

Ratio Mode: In Ratio mode, the speed potentiometer determines the ratio of the input signal. The input signal is setting the maximum speed and the speed potentiometer is setting the output as a ratio of that maximum speed. For example, if a 5 VDC signal is applied to the drive, the maximum speed is set to 50% (since the drive accepts a 0 - 10 VDC range). The speed potentiometer will then vary between 0% and 50% over its full range. This is useful in applications where fine tuning is made at the control, or where one common voltage signal is sent to multiple drives and each drive needs to be individually adjusted.

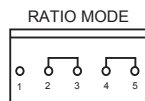
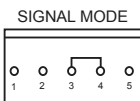
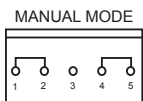

MANUAL MODE

SIGNAL MODE

RATIO MODE

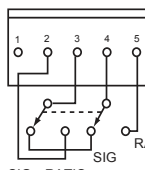
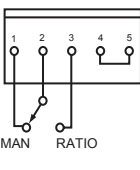
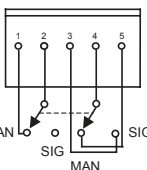

MAN / SIGNAL SWITCH

MAN / RATIO SWITCH

SIGNAL / RATIO SWITCH

STARTUP

- Verify that no foreign conductive material is present on the printed circuit board.
- Ensure that all switches and jumpers are properly set.

1. Turn the speed adjust potentiometer to "0" (CCW) and set the analog signal to minimum.
2. Apply AC line voltage.
3. If in Manual Mode, slowly advance the speed adjust potentiometer clockwise (CW). If in Signal Mode, slowly increase the analog signal. If in Ratio Mode, set the analog signal to maximum and slowly advance the speed adjust potentiometer clockwise (CW).
4. Remove AC line voltage from the drive to coast the motor to a stop.

Copyright 2013 by American Control Electronics® - All rights reserved. No part of this document may be reproduced or retransmitted in any form without written permission from American Control Electronics®. The information and technical data in this document are subject to change without notice. American Control Electronics® makes no warranty of any kind with respect to this material, including, but not limited to, the implied warranties of its merchantability and fitness for a given purpose. American Control Electronics® assumes no responsibility for any errors that may appear in this document and makes no commitment to update or to keep current the information in this document.

Operation

DECELERATING & STOPPING

Decelerate to Minimum Speed

The switches shown below may be used to decelerate a motor to a minimum speed. Opening the switch on S3 or on POS decelerates the motor from set speed to a minimum speed determined by the MIN SPD or SIG MIN trim pot setting. If the MIN SPD or SIG MIN trim pot is set full CCW, the motor decelerates to zero speed when the switch is opened. By closing the switch, the motor accelerates to set speed.

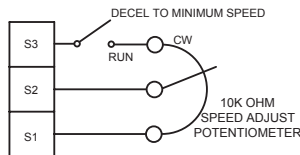

MANUAL OR RATIO MODE

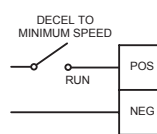

SIGNAL OR RATIO MODE

Decelerate to Zero Speed (Dynamic Brake)

Dynamic braking may be used to rapidly stop a motor. The MIN SPD trim pot must be set for zero speed. For the RUN/BRAKE switch, use a two pole, two position switch rated for at least the armature voltage rating and 150% of the armature current rating. For the dynamic brake resistor, use a 40 watt minimum, high power, wirewound resistor. Sizing the dynamic brake resistor depends on load inertia, motor voltage, and braking time. Use a lower-value, higher-wattage dynamic brake resistor to stop a motor more rapidly. Recommended values are 15 ohms for a 90 VDC motor and 30 ohms for 180 VDC motor.

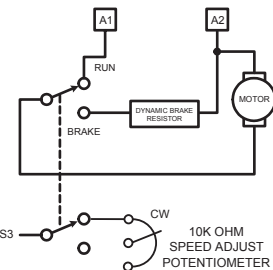

MANUAL OR RATIO MODE

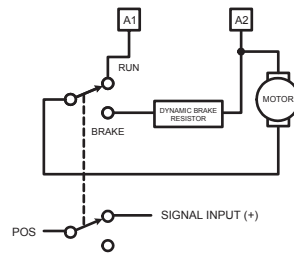

SIGNAL OR RATIO MODE

REVERSING

Reversing with a Dynamic Brake

A dynamic brake may be used when reversing the motor direction. The MIN SPD trim pot must be set for zero speed. Use a three pole, three position switch rated for at least the armature voltage rating and 150% of the armature current rating. For the dynamic brake resistor, use a 40 watt minimum, high power, wirewound resistor. Sizing the dynamic brake resistor depends on load inertia, motor voltage, and braking time. Use a lower-value, higher-wattage dynamic brake resistor to stop a motor more rapidly. Recommended values are 15 ohms for a 90 VDC motor and 30 ohms for 180 VDC motor.

The motor must come to a complete stop before changing directions.

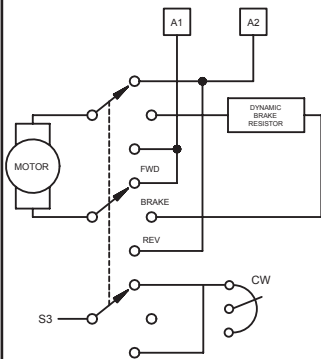

MANUAL OR RATIO MODE

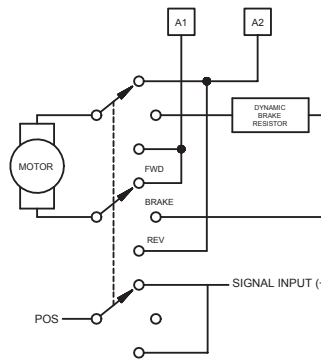

SIGNAL OR RATIO MODE

Calibration

Signal Minimum (SIG MIN): The SIG MIN setting determines the minimum motor speed when the input voltage or current signal is set for minimum speed. It only comes into effect in Signal or Ratio mode. It is factory set for zero speed. To calibrate the SIG MIN:

1. Set the SIG MIN trim pot full CCW.
2. If operation is in Ratio mode, set the speed adjust potentiometer full CCW.
3. Set the input voltage or current signal for minimum speed.
4. Adjust the SIG MIN trim pot until the desired minimum speed is reached or is just at the threshold of rotation.

Signal Maximum (SIG MAX): The SIG MAX setting determines the maximum motor speed when the input voltage or current signal is set for maximum speed. It only comes into effect in Signal or Ratio mode. To calibrate the SIG MAX:

1. Set the SIG MAX trim pot full CCW.
2. If operation is in Ratio mode, set the speed adjust potentiometer full CCW.
3. Set the input voltage or current signal for maximum speed.
4. Adjust the SIG MAX trim pot until the desired maximum speed is reached.

Check the SIG MIN and SIG MAX adjustments after recalibrating to verify that the motor runs at the desired minimum and maximum speed.

Minimum Speed (MIN SPD): The MIN SPD setting determines the minimum motor speed when the speed adjust potentiometer is set for minimum speed. It only comes into effect in Manual mode. It is factory set for zero speed. To calibrate the MIN SPD:

1. Set the MIN SPD trim pot full CCW.
2. Set the speed adjust potentiometer for minimum speed.
3. Adjust the MIN SPD trim pot until the desired minimum speed is reached or is just at the threshold of rotation.

Maximum Speed (MAX SPD): The MAX SPD setting determines the maximum motor speed when the speed adjust potentiometer is set for maximum speed. It only comes into effect in Manual mode. To calibrate the MAX SPD:

1. Set the MAX SPD trim pot full CCW.
2. Set the speed adjust potentiometer for maximum speed.
3. Adjust the MAX SPD trim pot until the desired maximum speed is reached.

Check the MIN SPD and MAX SPD adjustments after recalibrating to verify that the motor runs at the desired minimum and maximum speed.

Torque (TORQUE): The TORQUE setting determines the maximum torque for accelerating and driving the motor. To calibrate the TORQUE:

1. With the power disconnected from the drive, connect a DC ammeter in series with the armature.
2. Set the TORQUE trim pot to minimum (full CCW).
3. Set the speed adjust potentiometer (full CW) or input voltage or current signal to maximum speed (full CW).
4. Carefully lock the motor armature. Be sure that the motor is firmly mounted.
5. Apply line power. The motor should be stopped.
6. Slowly adjust the TORQUE trim pot CW until the armature current is 150% of motor rated armature current. **Continuous operation beyond this rating may damage the motor.**
7. Turn the speed adjust potentiometer CCW or decrease the input voltage or current signal.
8. Remove line power.
9. Remove the stall from the motor.
10. Remove the ammeter in series with the motor armature if it is no longer needed.

IR Compensation (IR COMP): The IR COMP setting determines the degree to which motor speed is held constant as the motor load changes. To calibrate the IR COMP:

1. Set the IR COMP trim pot full CCW.
2. Increase the speed adjust potentiometer or input voltage or current signal until the motor runs at midspeed without load. A handheld tachometer may be used to measure motor speed.
3. Load the motor armature to its full load armature current rating. The motor should slow down.
4. While keeping the load on the motor, rotate the IR COMP trim pot until the motor runs at the speed measured in step 2. If the motor oscillates (overcompensation), the IR COMP trim pot may be set too high (CW). Turn the IR COMP trim pot CCW to stabilize the motor.
5. Unload the motor.